

Operating and assembly instructions

AH 600-190

Extractor hood



GAGGENAU

AH 600-190

Preface

1. Important notes	Page 3-4
1.1 For your safety	Page 3
1.2 Operating for the first time	Page 4
1.3 About use	Page 4
2. Structure and operating principle	Page 5-6
2.1 Structure of the appliance	Page 5
2.2 Accessories/special accessories	Page 5
2.3 Operating principle	Page 6
3. Operation	Page 7-8
3.1 Switching on and off	Page 7
3.2 Special functions	Page 8
4. Cleaning and care	Page 9-10
5. Maintenance	Page 11
6. Assembly instructions	Page 12-17
6.1 Technical data	Page 12
6.2 Installation	Page 12-17

Preface



With your new extractor hood, working in the kitchen will be even more fun.

The appliance offers you a number of **advantages**:

- effective extraction thanks to the so-called "Coanda effect"
- low operating noise

To ensure that you will be able to use this appliance in all its diversity, read through the operating and assembly instructions conscientiously **before operating it for the first time**. The instructions contain **important notes** on use, installation and maintenance of the appliance.

On the following page you will find **important notes on safety and operation**. These will serve to ensure your personal safety and the lasting value of your appliance.

You will find notes on Page 4 that you ought to observe **before operating the appliance for the first time**.

The chapters entitled **"Structure and operating principle"** and **"Operation"** will tell you all the things your extractor hood is capable of doing and how the appliance is operated.

Tips and hints in the chapter entitled **"Cleaning and care"** will make sure that your appliance will stay operable and beautiful for a long time.

And now we wish you lots of fun with your new extractor hood.

1. Important notes

1.1 For your safety

- **Damaged appliances** must not be operated.
- The appliance must only be connected by an **authorised specialist**, paying attention to the relevant regulations of the power supply companies and the regional construction regulations.
Also observe the assembly instructions!
- **Connecting cables** must not come into contact with hot cooking surfaces.
- **Do not operate** the extractor hood without inserted lamps.
- Never operate the appliance **without a grease filter**.
- **Hazardous** or explosive substances and vapours must not be extracted!
- **The user** is responsible for expert use and the perfect condition of the appliance.
- Only ever operate the appliance under supervision.
- **Caution!** Over-greased filters are a fire risk! Only ever deep-fry under the extractor under constant supervision. Pay attention to cleaning the grease filter on a regular basis.
- **Fire risk!** Do not flambé meals under the extractor hood!
- Operation of the extractor hood **above a hearth for solid fuels** (coal or wood etc.) is only partly permitted.
- **Gas appliances** may only be used under the extractor hood when pots and pans are placed on them!
- When using **more than 3 gas-operated rings** at the same time, please operate the extractor hood at level 2 or higher. This prevents a build-up of heat in the appliance.
- **Do not place** any heavy objects on the appliance; this will have a detrimental effect on functioning.
- **Do not clean** the appliance with a steam cleaning apparatus or with water pressure because this poses a **risk of short-circuits**.
- Isolate the appliance from the mains **during every maintenance operation**. To do this, remove the mains plug or actuate the corresponding fuse.
If the mains plug is not accessible, the appliance must be deenergised by means of the domestic installation fuse.
- **Repairs** must be carried out by authorised specialists, thus ensuring electrical safety.
- **No warranty claims** can be lodged **in the event of damage** caused by failure to observe these instructions.
- Adequate incoming air must be ensured if a wood, coal, gas or oil heater or an open hearth is operated in the same room as the one in which the hood is installed.
- Safe operation is possible whenever the partial vacuum in the **place where the firing equipment is installed** does not exceed 4 Pa (0.04 mbar). This can be achieved whenever the air needed for combustion is able to enter through openings that cannot be sealed, for example in doors, windows, incoming/exhaust air wall boxes or other technical means.
- If the appliance is to be operated **only with the window open** (to ensure adequate incoming air), you can use the **window switch**. A switch (normally open) is fitted on the window. On the appliance, this switch is connected to the window switch terminal on the main electronics. The appliance can now only be operated when the window is open.
Important: the window switch must only be connected by an **authorised specialist**.
Note: The light function works without restriction.
- **After a power failure**, the extactor will not go on again automatically. You can recommence operation by turning a knob or by pressing any key.

Technical modifications reserved.

1.2 Operating for the first time

Before operating the appliance for the first time, please pay attention to the following notes:

- **The appliance** must be installed and connected by a specialist before it is operated for the first time.
- **The rating plate** for this appliance is included with the instructions on a separate sheet. Store the rating plate in the same location as your operating and assembly instructions. You need the rating plate for possible damage and warranty cases.
- **Conscientiously read** through the operating and assembly instructions before operating the appliance for the first time.
- **Remove the packaging** from the appliance and dispose of it properly. Pay **attention** to the fact that there are accessories in the packaging. Keep packaging elements out of the reach of children!
- **Thoroughly clean** the appliance before using it for the first time. (see chapter entitled "Cleaning and care").
- **Before operating** the appliance for the first time, check that the mains connection is in proper working order.

1.3 About use

- **The appliance is intended** solely for use in the household and must not be put to any other uses.
- **In the event of malfunctions**, first of all check the household fuses. If the problem has nothing to do with the power supply, please contact your specialist dealer or your local Gaggenau after-sales service.

2. Structure and operating principle

2.1 Structure of the appliance

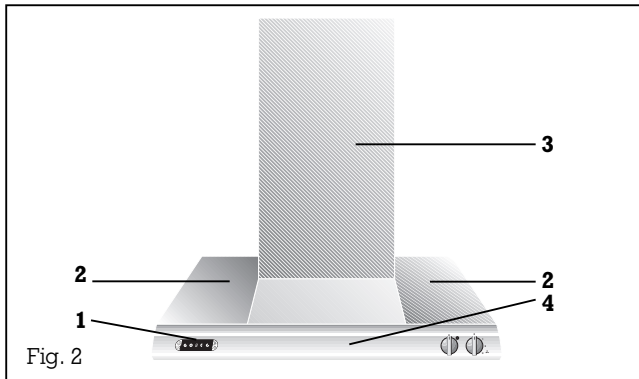

- 1 Display
- 2 Glass plates
- 3 Air duct
- 4 Control panel

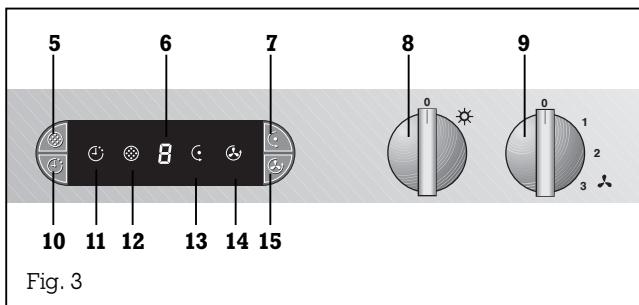

- 5 Grease filter key
- 6 Ventilation level display
- 7 "Coanda level" key
- 8 "Light" control knob
- 9 "Ventilation level" control knob
- 10 "After-running" key
- 11 "After-running" symbol
- 12 "Grease filter saturation" symbol
- 13 "Coanda level" symbol
- 14 "Intensive level" symbol
- 15 "Intensive level" key

2.2 Accessories/special accessories

You can order the following special accessories:

- Activated charcoal filter: **KF 600-090**
- Back draught flap **RK 040-150**: Back draught flap for insertion in the extractor's blow-out opening
- Flexible aluminium pipe **AR 040-150**:
DN 150 up to 3.5 m
Length with 2 hose clamps:

Installation accessories:

Exhaust air:

Ventilation duct for ceiling heights of 2.27 - 2.60 m:

LK 600-010

Ventilation duct for ceiling heights of 2.61 - 3.00 m:

LK 600-020

Air recirculation:

Ventilation duct for ceiling heights of 2.39 - 2.60 m:

LK 600-110

Ventilation duct for ceiling heights of 2.61 - 3.00 m:

LK 600-120

2.3 Operating principle

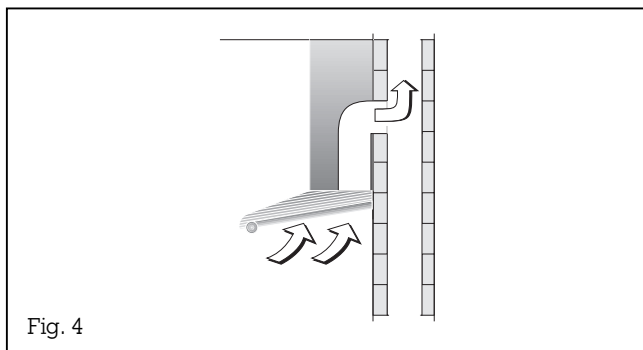

This extractor hood swiftly and silently extracts all odours produced while cooking. You can set different intensity levels depending on the intensity of odours.

The exhaust air first passes through the integrated grease filter. The grease filter intercepts and traps the grease and odour particles in the air.

In the exhaust air mode:

The fan in the extractor hood sucks in the kitchen vapours and passes them through the grease filter to outdoors. The grease filter absorbs the greasy components in the kitchen vapours (see Fig. 4).

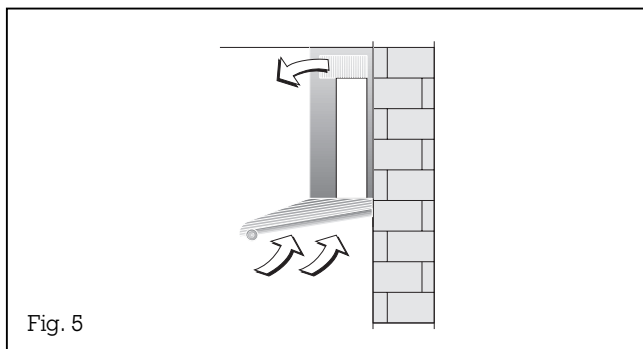

In the air recirculation mode:

An activated charcoal filter (special accessory) must be installed. The fan in the extractor hood sucks in kitchen vapours and returns them to the kitchen after purification in the grease and activated charcoal filter. The grease filter absorbs the greasy components in the kitchen vapours. The activated charcoal filter binds odour particles (see Fig. 5).

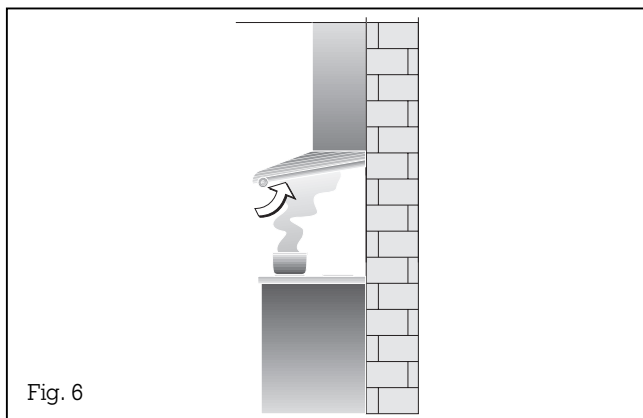

The "Coanda effect"

Kitchen vapours are extracted even better with the "Coanda effect". By means of an additional motor, kitchen vapours are passed swiftly and effectively into the hood's extraction zone. An additional fan on the front edge of the kitchen extractor hood generates an air stream that is diverted around a cylinder towards the rear. This ensures that kitchen vapours are routed completely into the extractor hood's filter area (see Fig. 6).

3. Operation

3.1 Switching on and off

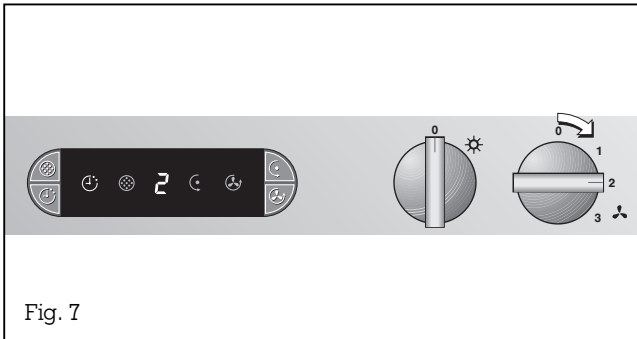

Fig. 7

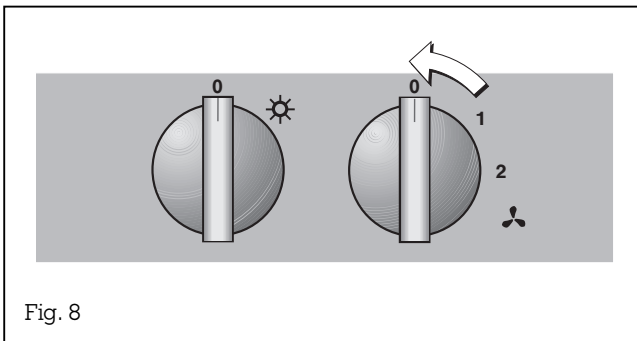

Fig. 8

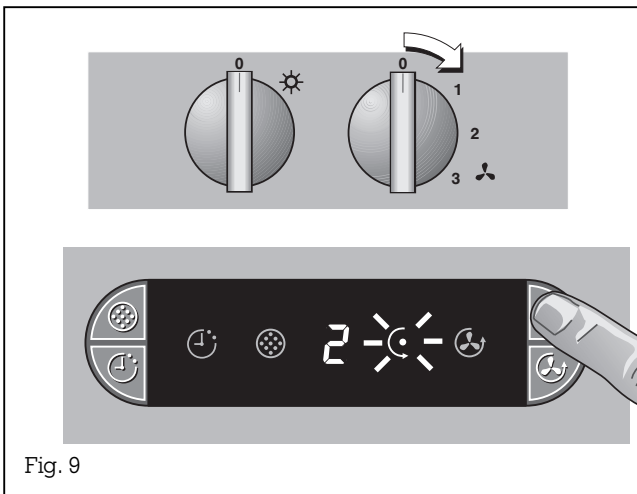

Fig. 9

Switching on

- Turn the "Ventilation level" control knob to the ventilation level you require (Fig. 7).
- The set level is displayed.

Switching off

- Turn the "Ventilation level" control knob to the 0 position (Fig. 8).
- The set level 0 is displayed for a few seconds.

Note:

The light can be switched on and off at any time. To do this, turn the "Light" control knob to the ☀ (Light) position.

Switching on the Coanda level

- Turn the "Ventilation level" control knob to the level you require.
- Press the Coanda level key.
- The level you have set and the Coanda level symbol appear on the display (Fig. 9).

Note: You can change to any ventilation level, and the Coanda level remains set.

Switching off the Coanda level:

- Press the "Coanda level" key or turn the "Ventilation level" knob to the 0 position.

3.2 Special functions

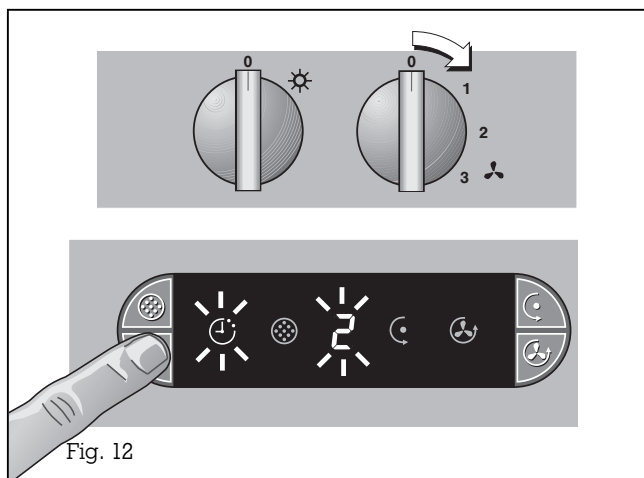
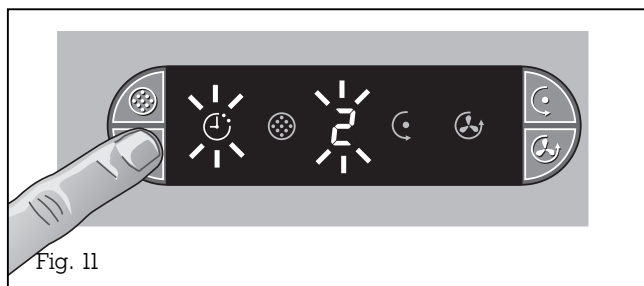
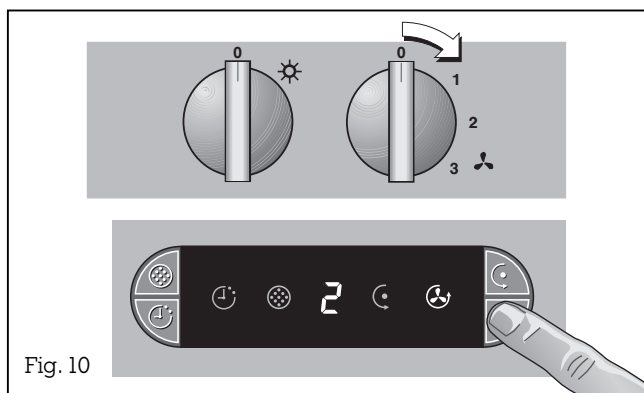

Intensive level

You should select the intensive level when browning and frying in an open pan.

Switching on: (Fig. 10)

- Turn the control knob to a ventilation level (1-3).
- Press the intensive level key. The intensive level symbol appears on the display. The previously selected ventilation level flashes on the display. After a few minutes, the appliance switches back automatically to the previously selected ventilation level.

or

- Press the intensive level key. The intensive level symbol appears on the display. The appliance is now operated at the intensive level for a few minutes and then switches off automatically.

Ending the intensive level prematurely:

- Turn the "Ventilation level" knob to the 0 position
- or
- turn the "Ventilation level" knob to any level or
- press the intensive level key once again.

After-running

Switching on:

- Press the ☀ (After-running) key.
- The ☀ (After-running) symbol and ventilation level 2 light up on the display (Fig. 11).

or

- Turn the "Ventilation level" control knob to any level.
- Press the ☀ (After-running) key.
- The ☀ (After-running) symbol and the set ventilation level light up on the display (Fig. 12).
- The extractor hood continues running for 10 minutes.

Switching off:

- Turn the "Ventilation level" control knob to the 0 position.

or

- Press the ☀ (After-running) key.

4. Cleaning and care



Fig. 13

Note:

The handles of the grease filters must be visible after installation. They can no longer be removed if the handles are in the inner part of the housing.

Cleaning the grease filters:

The ☉ (Grease filter saturation) symbol flashes on the display after an operating time of 30 hours. Flashing of this symbol signals to you that the grease filters have to be cleaned. The grease filters can be cleaned at any time, even if the ☉ (Grease filter saturation) symbol does not flash. The metal filters can be removed easily for cleaning.

Proceed as follows:

- Grip the grease filter handles and press the slide towards the rear.
- Pull the grease filter out of its mount in the downward direction (Fig. 13).
- Repeat the operation with the other grease filters.

You can clean the metal grease filters in a dishwasher at a maximum temperature of 65 °C. Place the grease filters vertically in the dishwasher to ensure that no food remainders will stay on them.

Slight discoloration can occur when cleaning the grease filters in a dishwasher.

When replacing the grease filters, wipe out the inner part of the housing with hot detergent solution.

Reinsert the grease filters in the hood after cleaning. Install them in the reverse order to removal.

Press the ☉ (Grease filter) key to set the elapsed hours counter to zero; the ☉ (Grease filter) symbol stops flashing.

Do not clean the appliance with a steam cleaning apparatus or with water pressure because this poses a **risk of short-circuits**.



Fig. 14

Air recirculation

If, when purchasing the extractor hood, you have decided in favour of the air recirculation mode, the activated charcoal filter KF 600-090 must be replaced after a certain amount of hood operation. Note: The activated charcoal filter is not included in the scope of delivery of the hood.

Activated charcoal filters do not contain any polluting substances. Old activated charcoal filters can be disposed of as domestic waste. If used once daily, the activated charcoal filter must be replaced approximately once to twice every year. First remove the grease filter. Press out the two tabs in the downward direction and remove the activated charcoal filter from the hood in the downward direction (see Fig. 14). Replace the old activated charcoal filter by the new one. Install in the reverse order.

Cleaning the extractor hood

Clean the **stainless steel parts** of the extractor hood with mild rinsing detergent and apply stainless steel care agent to the metal surfaces using a soft cloth.

Clean the two **glass plates** in a dishwasher.

Do not use any strong or caustic cleaning agents or brushes and abrasive cleaner.

Do not use any abrasive sponges either. Use commercially available window cleaner and apply it to a soft, moist cloth.

Only clean the **switch panel** with a soft cloth. Do not use any cleaning agent as it might be aggressive to the inscription markings.

5. Maintenance

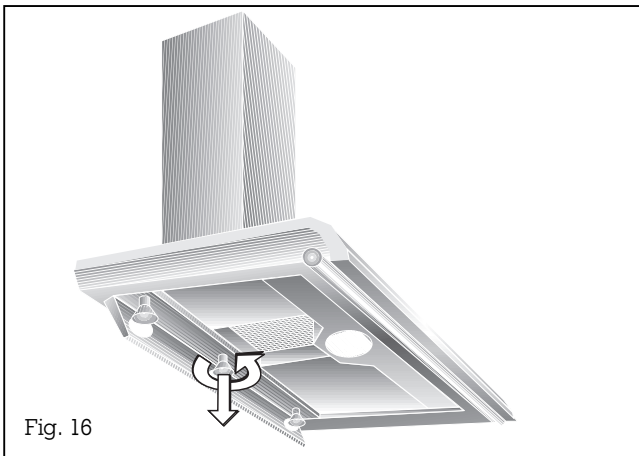
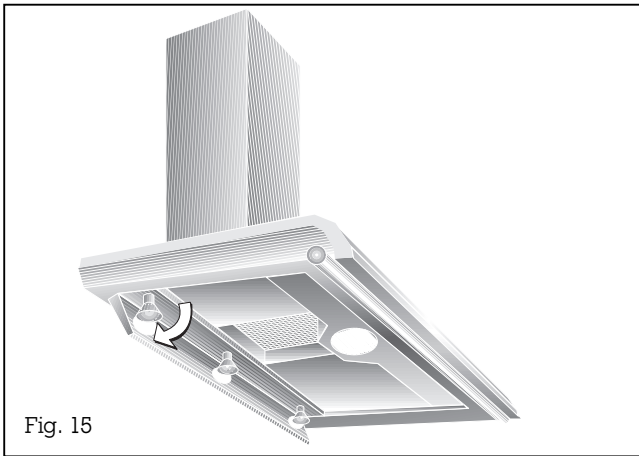

First disconnect the appliance from the mains **before carrying out any repairs.**

In the event of malfunctions, first of all check the household fuses.

If the **power supply** is in proper working order, but the appliance is nevertheless not functioning, then please contact your specialist dealer or your responsible Gaggenau after-sales service.

Specify the appliance type (see rating plate).

Repairs must only be carried out by authorised specialists, thus ensuring the safety of the appliance. Improper tampering will render all warranty claims null and void.

Lamp replacement

Caution: Disconnect the power supply before replacing lamps!

Caution: Lamps may still be hot shortly after use! Risk of burns.

- Remove the grease filters.
- Remove the screws on the lamp cover. The lamp cover tilts down and cannot be removed from the appliance (Fig. 15).
- Turn the lamp to the left and remove the lamp (Fig. 16).

Defective lamps must only be replaced by lamps of the same type (Cool Beam)! You can obtain the original spare part (No. 03602611) from trade dealers or via Gaggenau after-sales service.

Inserting the lamp

- Insert the lamp and turn it to the right.
- Screw down the lamp cover again.
- Connect the appliance to the mains again.

6. Assembly instructions

6.1 Technical data

Weight: 28 kg

Dimensions: 898 x 520 mm

Electrical connection

Pay attention to the rating plate data.

The mains connecting cable must at least correspond to the type H 05 VV-F G 0,75.

When replacing the mains cable, you must dismantle the tubular connection piece (undo 2 screws).

The appliance must only be connected by an **authorised specialist**. The specialist is responsible for perfect functioning of the appliance at its installation location. He must explain the operating principle of the appliance to the user with reference to the operating instructions. He must explain to the user how the appliance can be isolated from the mains whenever required.

Connection possibilities

The extractor hood was conceived for the exhaust air or air recirculation mode. The exhaust air can be routed into a separate exhaust air shaft or directly into the open through the outside wall.

The connector of the connecting cable is connected to the socket that is located behind the duct cover on the wall. If this is not possible, it must be possible to isolate all poles of the appliance from the mains by way of the domestic fuse, or by means of accessible isolating device with a contact gap of at least 3 mm.

AH 600-190	FD xxxx	xxxx	
AC 220-240V	50Hz	345W	xxxx
Ⓜ 160W	Ⓜ 35W	⚡ 3x50W	

6.2 Installation

The applicable regulations of the energy supply companies and the **regional construction regulations** must be observed when installing the hood.

The minimum distance from the worktop to the bottom edge of the wall hood is for electrical appliances 600 mm and for gas appliances 670 mm.

The wall hood was conceived for the **exhaust air or air recirculation mode**. The exhaust air can be routed into a separate exhaust air shaft or directly into the open through the outside wall.

It is not allowed to pass the exhaust air into a flue or exhaust air chimney that is in operation or into a shaft that is linked to the heating basement. Consult the chimney sweep responsible for your district whenever you wish to pass the exhaust air into a chimney that is not in operation.

During the course of planning, a chimney sweep must be consulted if a room air-dependent hearth is operated in the same room as the one in which a hood is operated in the exhaust air mode. Adequate incoming air must be ensured. The applicable construction and safety regulations must be observed.

Adequate incoming air must be ensured if a wood, coal, gas or oil heater or an open hearth is operated in the same room as the one in which the hood is installed.

Safe operation is possible whenever the partial vacuum in the place where the firing equipment is installed does not exceed 4 Pa (0.04 mbar). This can be achieved whenever the air needed for combustion is able to enter through openings that cannot be sealed, for example in doors, windows, incoming/exhaust air wall boxes or other technical means.

Flexible aluminium pipes, corrosion-protected sheet metal pipes and **exhaust air** pipes whose material conforms to fire B1 in accordance with DIN 4102 can be used. Exhaust air pipes should have a nominal diameter of 150 mm.

Pay particular attention to ensuring that

- the exhaust air ducts and pipes are kept as short as possible
- the pipes are not laid at an acute angle, but as bends and that they are inserted into the shaft at an inclined upward angle and
- there are no cross-sectional constrictions in the upward direction (this reduces the volume flow).

As **standard**, the blow-out opening of the wall hood is in the upward direction.

To pass exhaust air through the outer wall, we recommend the use of our telescopic wall box TM 150-045 (Ø 150).

Note:

To prevent the ingress of water, e.g. condensate or rain water from an uncovered exhaust air shaft, our condensate separator RV 060-150 must be installed in the exhaust air line. The condensate separator must still be accessible after installation.

Air recirculation

You need the following **accessories** to install the air recirculation hood:

- **KF 600-090:** activated charcoal filter:

Depending on the ceiling height, the following duct units are at your disposal for air recirculation:

- **LK 600-110:** Ventilation duct for a ceiling height of 2.39 - 2.60 m
- **LK 600-120:** Ventilation duct for a ceiling height of 2.61 - 3.00 m

The dimensions above refer to a distance of 1.60 m from the floor to the bottom edge of the hood.

Exhaust air operation

Depending on the ceiling height, the following duct units are at your disposal for exhaust air operation:

- **LK 600-010:** Ventilation duct for a ceiling height of 2.27 to 2.60 m
- **LK 600-020:** Ventilation duct for a ceiling height of 2.61 - 3.00 m

The dimensions above refer to a distance of 1.60 m from the floor to the bottom edge of the hood.

If required, a side outlet for the air duct is available at an extra charge.

The socket must be placed behind the duct cover on the wall.

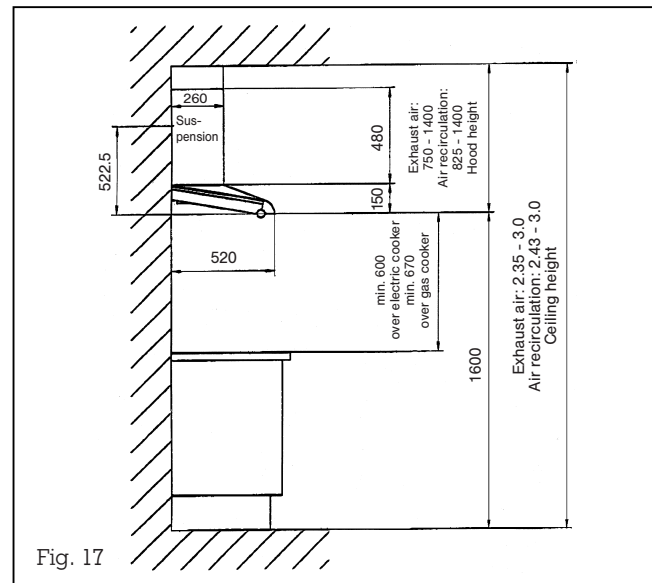

Fig. 17

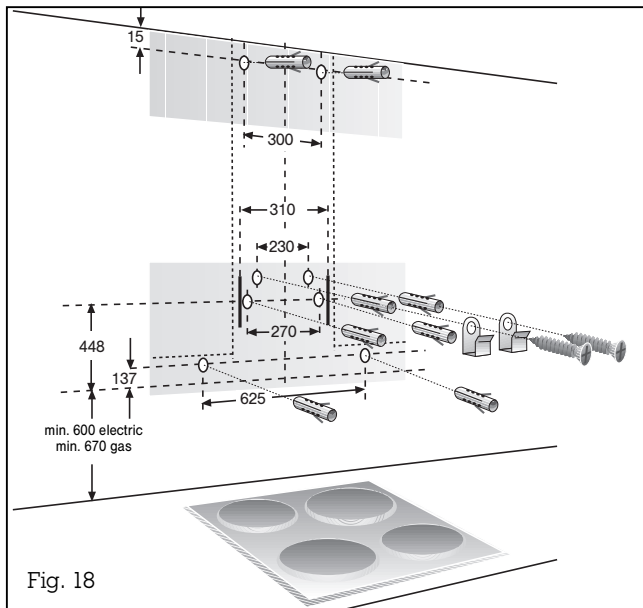

Fig. 18

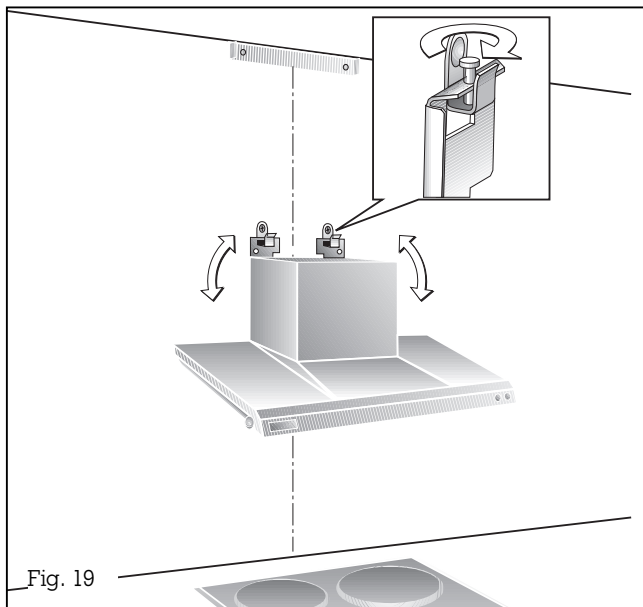

Fig. 19

Proceed as follows:

Important: Before marking the securing holes, make sure that no electricity or water lines or other lines are laid at the drilling points in the wall.

Exhaust air operation:

- From the bottom edge of the hood, mark a center line on the wall.
- With the aid of the drilling template, mark the positions of the screws on the wall. Mark the contour of the hook-in area. This will make it easier to hook in the hood (Fig. 18).
- Pay attention to the minimum clearance of 600 mm for electric cookers and 670 mm for gas cookers. The bottom edge of the template corresponds to the bottom from edge of the hood.
- Using the drilling template, drill the 6 holes for the hood (area I of the drilling template) and the two holes for suspending the chimney (area II of the drilling template). In the top two securing holes for the hood, fix the two hooks **e** with the countersunk screws **d**. Make sure that the hooks lie flatly on the wall. In certain circumstances you may have to countersink the drill holes. Fit the included dowels **a** in the other drill holes.

Note: Pay attention to any special accessories that you may have to fit.

- Screw on the retaining bracket for the chimney paneling.
- Detach the grease filters.
- Unscrew the two black plates on the left and right of the chimney.
- Hang the hood on the two hooks. Adjust the suspended element with the recessed head screw and align the hood using a spirit level (Fig. 19).

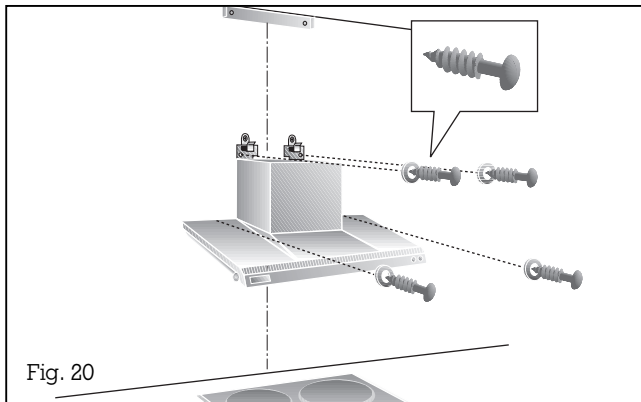

Fig. 20

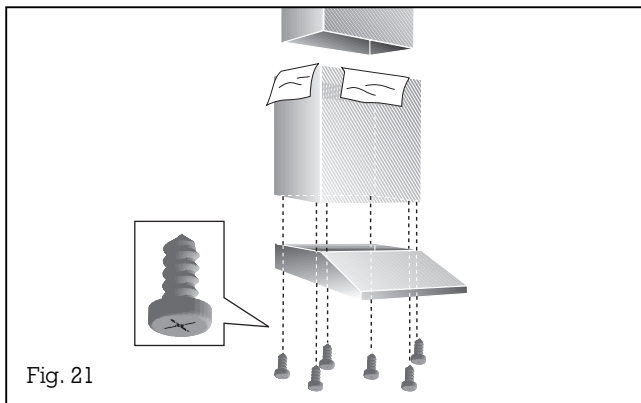

Fig. 21

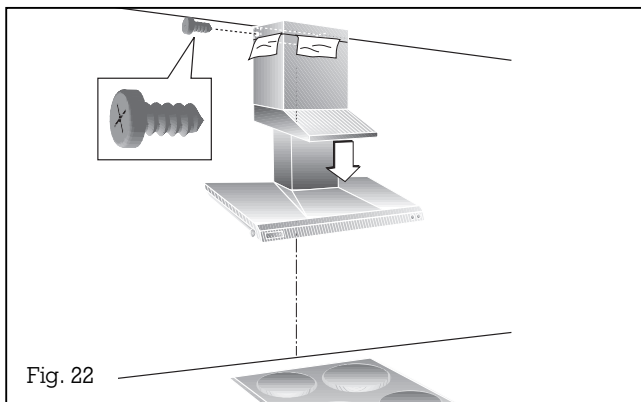

Fig. 22

- Secure the hood to the wall using the 4 screws **b** with shims **c** (Fig. 20).
- Establish the pipe connection.
- Establish the electrical connection.
- Extract the protective file from the chimney paneling.

Note: Avoid damaging the sensitive stainless steel surfaces.

- Join the chimney shoe with the chimney base using the 6 screws (3.5 x 9.5 mm) (Fig. 21).
- Fit the top of the chimney into the base. Make sure that the fastening holes on the side are at the top.
- Secure the top duct unit with 2 screws on the ceiling holder.
- Pull the shoe down into its final position (Fig. 22).

Note: Avoid scratches when fitting the elements into one another by placing the assembly template, for example, over the edge of the bottom chimney paneling to protect it.

- Reinsert the grease filters.
- Again screw in the two black plates on the left and right of the chimney.
- Place the glass plates on the black plates.

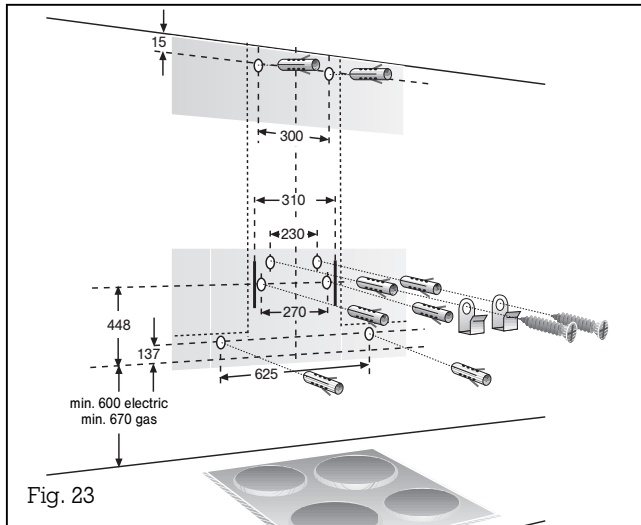

Fig. 23

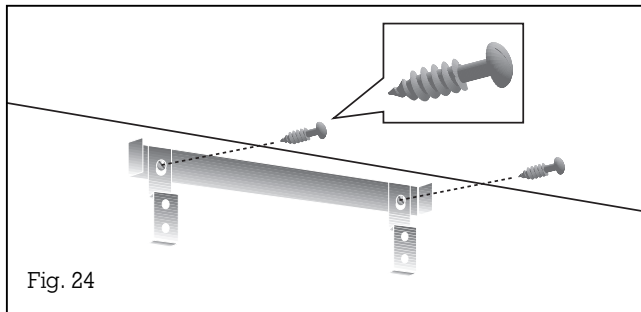

Fig. 24

Recirculation air operation

- From the bottom edge of the hood, mark a center line on the wall.
- With the aid of the drilling template, mark the positions of the screws on the wall. Mark the contour of the hook-in area. This will make it easier to hook in the hood (Fig. 23).
- Pay attention to the minimum clearance of 600 mm for electric cookers and 670 mm for gas cookers. The bottom edge of the template corresponds to the bottom from edge of the hood.
- Using the drilling template, drill the 6 holes for the hood (area I of the drilling template) and the two holes for suspending the chimney (area II of the drilling template). In the top two securing holes for the hood, fix the two hooks **e** with the countersunk screws **d**. Make sure that the hooks lie flatly on the wall. In certain circumstances you may have to countersink the drill holes. Fit the included dowels **a** in the other drill holes.

Note: Pay attention to any special accessories that you may have to fit.

- Detach the grease filters.
- Unscrew the two black plates on the left and right of the chimney.
- Hang the hood on the two hooks. Adjust the suspended element with the recessed head screw and align the hood using a spirit level (Figure 19).
- Secure the hood to the wall using the 4 screws **b** with shims **c**.
- Screw the retaining bracket for the chimney paneling onto the wall together with the two retaining brackets for the housing (air guidance) (Fig. 24).

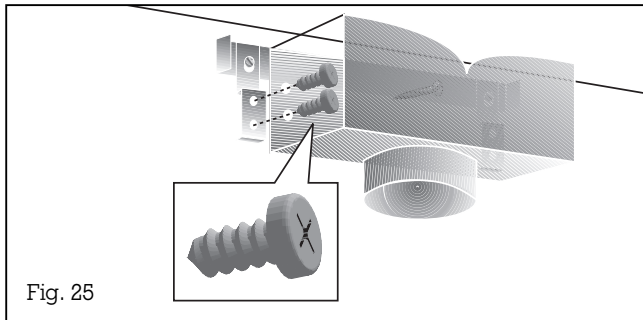

Fig. 25

- Screw together the air guidance housing and screw it onto the two retaining brackets (Fig. 25).
- Establish the pipe connection between the air connection piece and the air guidance housing.
- Establish the electrical connection.
- Stick the included sealing strips (8 strips) around the air slots on the top chimney paneling.
- Remove the protective foil from the chimney paneling.

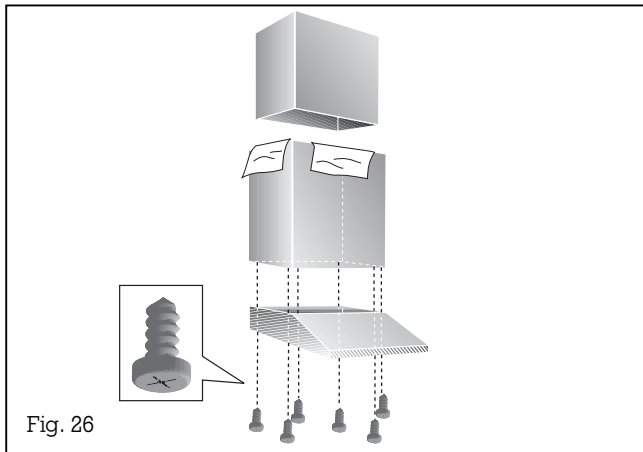

Fig. 26

- Note:** Avoid damaging the sensitive stainless steel surfaces.
- Join the chimney shoe with the chimney base using the 6 screws (3.5 x 9.5 mm) (Fig. 26).
 - Fit the top of the chimney into the base. Make sure that the fastening holes on the side are at the top.
 - Secure the top duct unit with 2 screws on the ceiling holder.
 - Pull the shoe down into its final position (Fig. 27)

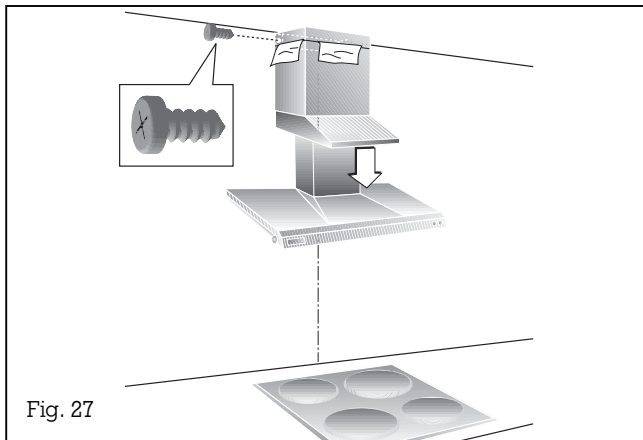

Fig. 27

- Note:** Avoid scratches when fitting the elements into one another by placing the assembly template, for example, over the edge of the bottom chimney paneling to protect it.
- Make sure that an **activated charcoal filter** is installed (see page 10).
 - Reinsert the grease filters.
 - Again screw in the two black plates on the left and right of the chimney.
 - Place the glass plates on the black plates.

GAGGENAU

GAGGENAU HAUSGERÄTE GMBH
P.O. BOX 10 02 50 · D-80076 MÜNCHEN
☎ (0 89) 45 90-01
FAX (0 89) 45 90-23 47

GAGGENAU

GAGGENAU HAUSGERÄTE GMBH
P.O. BOX 12 60 · D-76568 GAGGENAU, GERMANY
☎ (0 72 25) 9 67-0 · FAX (0 72 25) 9 67-190
☎ (0 18 01) 11 22 11 (KUNDENDIENST) · ☎ (0 18 01) 33 53 04 (ERSATZTEILE)
www.gaggenau.com